



Bridage DIN
Bridage rapide Sauterelles
Flexibles d'arrosage
Lampes pour machine-outil
Outillage

Pieds pour machine-outil

Goupilles DIN
Plots anti-vibratoires
Canons de perçage DIN
Clavettes DIN
Goupilles élastiques

PIED CAOUTCHOUC - ACIER

- C'est le modèle le plus standard. Il est fabriqué à partir de caoutchouc synthétique d'une dureté de 65-70 shores.
- Il s'adapte aux nécessités modernes des machines à vibrations peu nombreuses, de fréquence moyenne et haute, et à des sols plats.

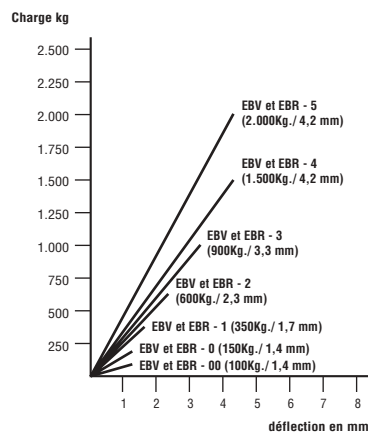

Forme A
à vis traversante

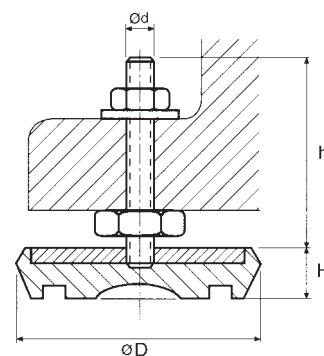

Forme A



Forme B
à tige filetée sur rotule

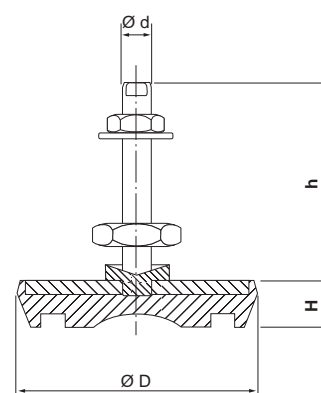

Forme B

$$* \text{ charge par support} = \frac{\text{Poids machine}}{\text{nbre de pieds}}$$

Référence	Forme	* Charge en kg mini	* Charge en kg maxi	ØD (mm)	H (mm)	h (mm)	Ød (mm)	Poids (g)
Forme A								
EBV-000	A	0	60	42	15	37	M8	70
EBV-00	A	30	100	63	18	83	M10	225
EBV-0	A	80	150	70	22	90	M12	365
EBV-1	A	100	350	90	26	90	M12	600
EBV-2	A	300	600	108	30	110	M16	945
EBV-3	A	500	900	127	34	110	M16	1310
EBV-4	A	800	1500	150	38	110	M16	2015
EBV-5	A	1300	2000	170	42	110	M16	2560
Forme B								
EBR-000	B	0	60	42	15	37	M8	70
EBR-00	B	30	100	63	18	83	M10	225
EBR-0	B	80	150	70	22	90	M12	365
EBR-1	B	100	350	90	26	90	M12	600
EBR-2	B	300	600	108	30	110	M16	945
EBR-3	B	500	900	127	34	110	M16	1310
EBR-4	B	800	1500	150	38	110	M16	2015
EBR-5	B	1300	2000	170	42	110	M16	2560

PIED CAOUTCHOUC - ACIER INOXYDABLE

- La fabrication à partir d'un caoutchouc synthétique d'une dureté de 65-70 shore.
- Le dessin du support qui permet une adhérence au sol optimum, confèrent à ce pied fabriqué en acier inoxydable A-2 (AISI 304) une utilisation particulièrement adapté à l'industrie agro-alimentaire et chimique.



Forme A
à vis traversante

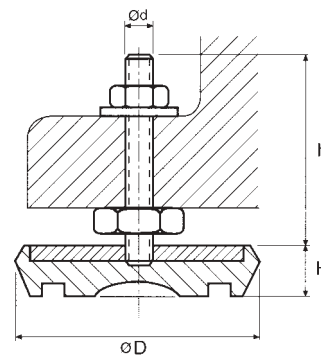
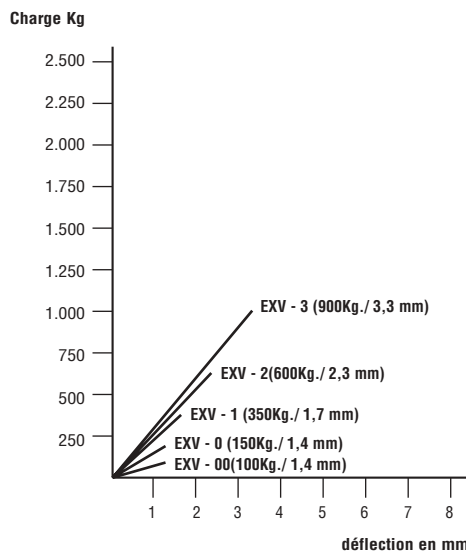

Forme A

$$* \text{ charge par support} = \frac{\text{Poids machine}}{\text{nbre de pieds}}$$

Référence	* charge en Kg		ØD (mm)	H (mm)	h (mm)	Ød (mm)	Poids (g)
	mini	maxi					
EXV-000	0	60	42	15	37	M8	70
EXV-00	30	100	63	18	83	M10	225
EXV-0	80	150	70	22	90	M12	365
EXV-1	100	350	90	26	90	M12	600
EXV-2	300	600	108	30	110	M16	945
EXV-3	500	900	127	34	110	M16	1310

PIED EN POLYURETHANE - ACIER

- Ce sont des supports de haute résistance qui combinent une grande absorption d'efforts avec peu de déflexion et une adhérence maximale.
- Fabriqué en polyurethane (thermoplastique) d'une dureté de 80-85 shores et en fonte d'acier GGG-40
- Cette gamme est particulièrement adaptée aux machines lourdes avec des conditions où les agents chimiques exercent une action destructive importante.

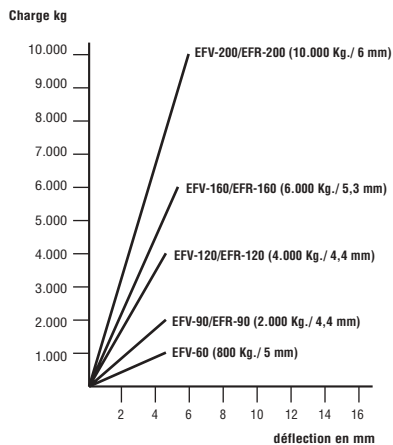

Forme A
à tige traversante

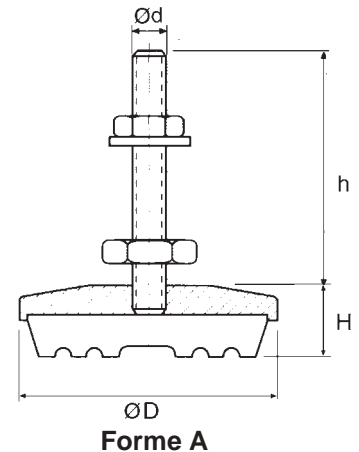

Forme B
à tige filetée sur rotule

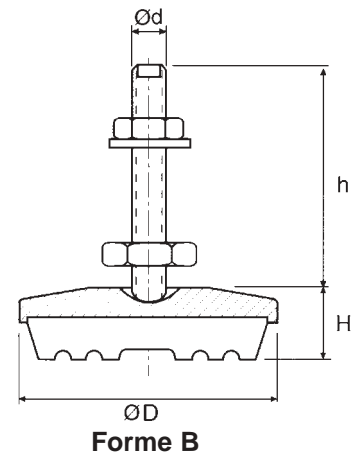

$$* \text{ charge par support} = \frac{\text{Poids machine}}{\text{nbre de pieds}}$$

Référence	Forme	* Charge en kg		Matière	ØD (mm)	H (mm)	h (mm)	Ød (mm)	Poids (g)
		mini	maxi						
Forme A									
EFV-60	A	200	800	Polyurethane	65	27	90	M12	385
EFV-90	A	500	2000	Polyurethane	100	30	110	M16	835
EFV-120	A	2000	4000	Polyurethane	123	33	120	M20	1415
EFV-160	A	4000	6000	Polyurethane 80	173	40	115	M20	2750
EFV-200	A	5000	10000	Polyurethane 90	217	48	145	M24	5475
Forme B									
EFR-90G	B	80	300	Caout 70	100	30	120	M12	605
EFR-120G	B	150	500	Caout 70	123	31	120	M16	1285
EFR-90	B	500	2000	Polyurethane 80	100	30	120	M16	850
EFR-120	B	2000	4000	Polyurethane 80	123	33	130	M20	1430
EFR-160	B	4000	6000	Polyurethane 80	173	40	130	M20	2770
EFR-200	B	5000	10000	Polyurethane 90	217	48	150	M24	5450

PIED EN POLYURETHANE - ACIER INOXYDABLE

- Pied en polyuréthane , acier mais fabrication en inox A2 (AISI 304)



Forme A
à vis traversante

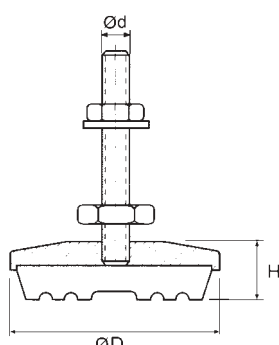

Forme A

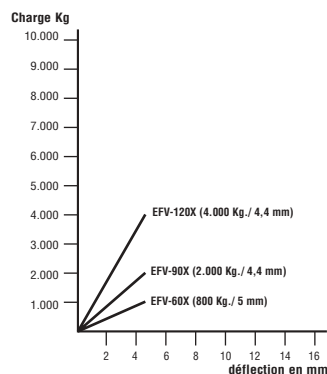

$$* \text{ charge par support} = \frac{\text{Poids machine}}{\text{nbre de pieds}}$$

Référence	*charge en Kg		ØD (mm)	H (mm)	Ød (mm)	Poids (gr)
	mini	maxi				
EFV-60X	200	800	65	27	M12	385
EFV-90X	500	2000	100	30	M16	835
EFV-120X	2000	4000	123	33	M16	1415

PIED CAOUTCHOUC - ACIER - série LOURDE

- Ce support est constitué d'un couvercle circulaire, d'une base en caoutchouc synthétique (70-80 shores) qui confèrent aux pieds les avantages suivants :

- Protection du caoutchouc contre la corrosion par un couvercle acier qui sert à son tour de siège stable pour les pattes de la machine.
- Forte adhérence aux sols et une mise en place rapide et facile.

- Ce type de support est particulièrement conseillé pour les machines lourdes à vibrations puissantes et/ou aux chocs aussi bien horizontaux (injections plastique) que verticaux (presses, cisailles, guillottes).

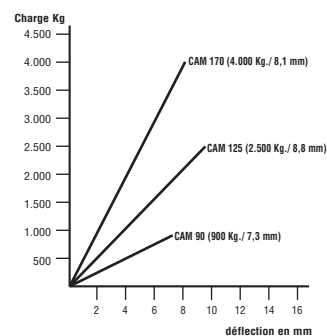
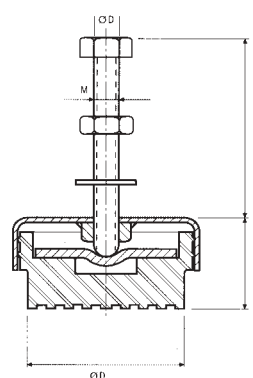

$$* \text{ charge par support} = \frac{\text{Poids machine}}{\text{nbre de pieds}}$$

Référence	*charge en Kg		ØD (mm)	H (mm)	h (mm)	Ød (mm)	Poids (g)
	mini	maxi					
ECAM-50	0	100	49	24	40	M 8	100
ECAM-75	100	350	75	35	75	M10	650
ECAM-85	350	600	90	40	90	M12	760
ECAM-90	600	900	90	48	100	M16	865
ECAM-125	900	2500	125	57	120	M16	1800
ECAM-170	2500	4000	168	57	130	M20	3310

TAPIS ANTIVIBRATOIRES - ANTIGLISSANT

- Fabriqués à partir de caoutchouc synthétique ou polyuréthane, les types 2 et 3 sont étudiés pour être prédécoupés en 4 morceaux égaux.
- Ils sont adaptés tant par leur profil que par la dureté du caoutchouc à supporter des charges variant de 20 à 2000 Kg par 100 cm².

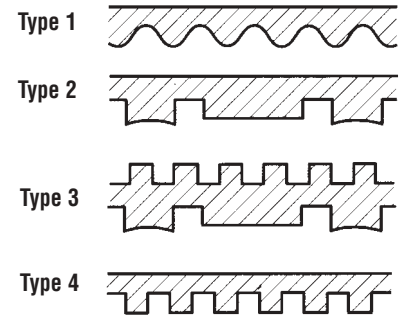

Référence	type	dimensions (mm)	Dureté (shore)	charge Kg/cm ²	Poids (g)
EA-300	1	300X300X10	caout 50	20-100	790
EADS-50	2	400x400x14	caout 50	80-300	1705
EADS-70	2	400x400x14	caout 70	200-600	1860
EADD-50	3	400x400x17	caout 50	80-300	1860
EADD-70	3	400x400x17	caout 70	200-600	2010
EAL -POLY	4	400x400x12	polyureth	700-2000	1475

CALES réglables

- Destinées à assurer une mise à niveau parfaite ces 2 types de cales sont particulièrement utilisés pour supporter les machines de grandes dimensions.

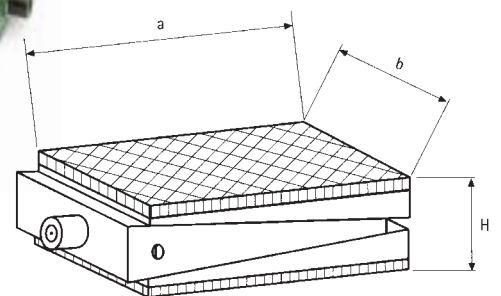

* charge par support = $\frac{\text{Poids machine}}{\text{nbre de pieds}}$

Référence	*charge adm. Kg	H de réglage (mm)	Dimensions axb	Matière (shore)	Poids (g)
E1C-70	500-1500	62-72	150x75	caout 70	3135
E1CA-90	700-2500	62-72	150x75	poly 90	3060
E2C-70	1500-3000	80-100	220x110	caout 70	9825
E2CA-90	3000-7000	80-100	220x110	poly 90	9765



Bridage DIN
Bridage rapide Sauterelles
Flexibles d'arrosage
Lampes pour machine-outil
Outillage

Plots anti-vibratoires

Goupilles DIN
Plots anti-vibratoires
Canons de perçage DIN
Clavettes DIN
Goupilles élastiques

PLOTS ANTIVIBRATOIRES - 50 shores

Cylindres type "T"

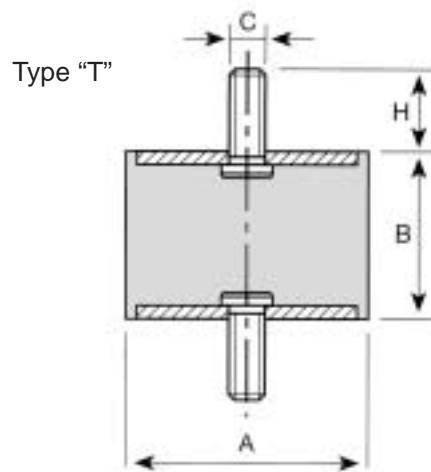

Référence	ØA (mm)	B (mm)	H (mm)	ØC (mm)	Compression Charge maxi (Kg)	Flèche maxi (mm)
T1010	10	10	10	M4	10	2
T1015	10	15	10	M4	8	3
T1608	16	8	12	M5	15	1,5
T1610	16	10	12	M5	20	1,5
T1615	16	15	12	M5	20	3
T1620	16	20	12	M5	20	4
T2010	20	10	13	M6	30	2
T2015	20	15	13	M6	25	3
T2020	20	20	18	M6	25	4
T2025	20	25	18	M6	25	5
T2510	25	10	20	M8	50	2
T2515	25	15	20	M8	50	3
T2520	25	20	20	M8	50	4
T2522	25	22	20	M8	50	4
T2525	25	25	20	M8	40	5
T2530	25	30	20	M8	35	6
T3015	30	15	20	M8	90	3
T3020	30	20	20	M8	90	4
T3025	30	25	20	M8	85	5
T3030	30	30	20	M8	80	6
T3040	30	40	20	M8	60	8
T3535	35	35	20	M8	90	8
T4020	40	20	25	M10	160	4
T4025	40	25	25	M10	150	6
T4028	40	28	25	M10	150	7
T4030	40	30	25	M10	150	8
T4040	40	40	25	M10	120	10

Référence	ØA (mm)	B (mm)	H (mm)	ØC (mm)	Compression Charge maxi (Kg)	Flèche maxi (mm)
T4045	40	45	25	M10	110	12
T5020	50	20	25	M10	250	4
T5030	50	30	25	M10	250	8
T5035	50	35	25	M10	230	9
T5040	50	40	25	M10	220	10
T5045	50	45	25	M10	210	11
T5050	50	50	25	M10	200	12
T6025	60	25	30	M10	400	5
T6035	60	35	30	M10	350	7
T6045	60	45	30	M10	300	10
T6060	60	60	30	M10	250	12
T7035	70	35	30	M10	450	7
T7050	70	50	30	M10	350	10
T7070	70	70	30	M10	300	13
T7525	75	25	35	M12	650	7
T7540	75	40	35	M12	500	9
T7545	75	45	35	M12	500	10
T7555	75	55	35	M12	450	13
T8030	80	30	35	M14	900	7
T8050	80	50	35	M14	750	10
T8070	80	70	35	M14	550	13
T10040	100	40	45	M16	1200	8
T10060	100	60	45	M16	1100	15
T10075	100	75	45	M16	1000	17
T15060	150	60	45	M16	2200	14
T15075	150	75	45	M16	2000	16

PLOTS ANTIVIBRATOIRES - 50 shores

Cylindres type "H"

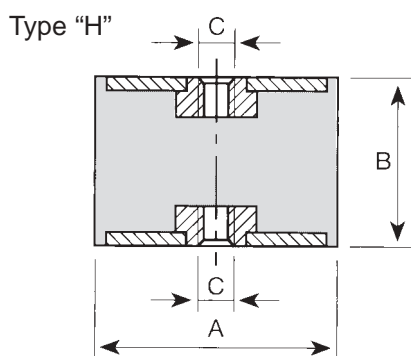

Référence	ØA (mm)	B (mm)	ØC (mm)	Compression	
				Charge maxi (Kg)	Flèche maxi (mm)
H1010	10	10	M4	10	2
H1015	10	15	M4	8	3
H1615	16	15	M5	20	3
H1620	16	20	M5	20	4
H2015	20	15	M6	25	3
H2020	20	20	M6	25	4
H2025	20	25	M6	25	5
H2515	25	15	M8	50	3
H2520	25	20	M8	50	4
H2522	25	22	M8	50	4
H2525	25	25	M8	40	5
H2530	25	30	M8	35	6
H3015	30	15	M8	90	3
H3020	30	20	M8	90	4
H3025	30	25	M8	85	5
H3030	30	30	M8	80	6
H3040	30	40	M8	60	8
H3535	35	35	M8	90	8
H4020	40	20	M10	160	4
H4025	40	25	M10	150	6
H4028	40	28	M10	150	7
H4030	40	30	M10	150	8
H4040	40	40	M10	120	10
H4045	40	45	M10	110	12
H5020	50	20	M10	250	4

Référence	ØA (mm)	B (mm)	ØC (mm)	Compression	
				Charge maxi (Kg)	Flèche maxi (mm)
H5030	50	30	M10	250	8
H5035	50	35	M10	230	9
H5040	50	40	M10	220	10
H5045	50	45	M10	210	11
H5050	50	50	M10	200	12
H6025	60	25	M10	400	5
H6035	60	35	M10	350	7
H6045	60	45	M10	300	10
H6060	60	60	M10	250	12
H7035	70	35	M10	450	7
H7050	70	50	M10	350	10
H7070	70	70	M10	300	13
H7525	75	25	M12	650	5
H7540	75	40	M12	500	9
H7545	75	45	M12	500	10
H7555	75	55	M12	450	13
H8030	80	30	M14	900	7
H8050	80	50	M14	750	10
H8070	80	70	M14	550	13
H10040	100	40	M16	1200	8
H10060	100	60	M16	1100	15
H10075	100	75	M16	1000	17
H15060	150	60	M16	2200	14
H15075	150	75	M16	2000	16

PLOTS ANTIVIBRATOIRES - 50 shores

Cylindriques type "TH"

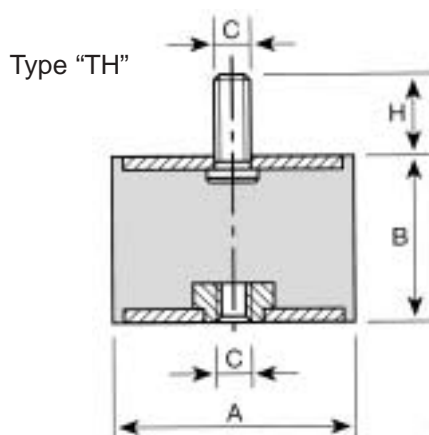

Référence	ØA (mm)	B (mm)	H (mm)	ØC (mm)	Compression Charge maxi (kg)	Flèche maxi (mm)
TH1010	10	10	10	M4	10	2
TH1015	10	15	10	M4	8	3
TH1608	16	8	12	M5	15	1,5
TH1610	16	10	12	M5	20	1,5
TH1615	16	15	12	M5	20	3
TH1620	16	20	12	M5	20	4
TH2010	20	10	13	M6	30	2
TH2015	20	15	13	M6	25	3
TH2020	20	20	18	M6	25	4
TH2025	20	25	18	M6	25	5
TH2510	25	10	20	M8	50	2
TH2515	25	15	20	M8	50	3
TH2520	25	20	20	M8	50	4
TH2522	25	22	20	M8	50	4
TH2525	25	25	20	M8	40	5
TH2530	25	30	20	M8	35	6
TH3015	30	15	20	M8	90	3
TH3020	30	20	20	M8	90	4
TH3025	30	25	20	M8	85	5
TH3030	30	30	20	M8	80	6
TH3040	30	40	20	M8	60	8
TH3535	35	35	20	M8	90	8
TH4020	40	20	25	M10	160	4
TH4025	40	25	25	M10	150	6
TH4028	40	28	25	M10	150	7
TH4030	40	30	25	M10	150	8
TH4040	40	40	25	M10	120	10

Référence	ØA (mm)	B (mm)	H (mm)	ØC (mm)	Compression Charge maxi (kg)	Flèche maxi (mm)
TH4045	40	45	25	M10	110	12
TH5020	50	20	25	M10	250	4
TH5030	50	30	25	M10	250	8
TH5035	50	35	25	M10	230	9
TH5040	50	40	25	M10	220	10
TH5045	50	45	25	M10	210	11
TH5050	50	50	25	M10	200	12
TH6025	60	25	30	M10	400	5
TH6035	60	35	30	M10	350	7
TH6045	60	45	30	M10	300	10
TH6060	60	60	30	M10	250	12
TH7035	70	35	30	M10	450	7
TH7050	70	50	30	M10	350	10
TH7070	70	70	30	M10	300	13
TH7525	75	25	35	M12	650	5
TH7540	75	40	35	M12	500	9
TH7545	75	45	35	M12	500	10
TH7555	75	55	35	M12	450	13
TH8030	80	30	35	M14	900	7
TH8050	80	50	35	M14	750	10
TH8070	80	70	35	M14	550	13
TH10040	100	40	45	M16	1200	8
TH10060	100	60	45	M16	1100	15
TH10075	100	75	45	M16	1000	17
TH15060	150	60	45	M16	2200	14
TH15075	150	75	45	M16	2000	16

BUTÉES SIMPLES - 50 shores

Cylindriques type "TS"

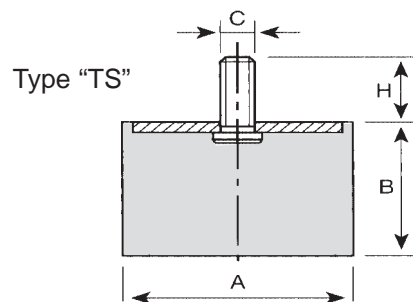

Référence	ØA (mm)	B (mm)	H (mm)	ØC (mm)	Compression Charge maxi (Kg)	Flèche maxi (mm)
TS1010	10	10	10	M4	10	2
TS1015	10	15	10	M4	8	3
TS1608	16	8	12	M5	15	1,5
TS1610	16	10	12	M5	20	1,5
TS1615	16	15	12	M5	20	3
TS1620	16	20	12	M5	20	4
TS2010	20	10	13	M6	30	2
TS2015	20	15	15	M6	25	3
TS2020	20	20	15	M6	25	4
TS2025	20	25	15	M6	25	5
TS2510	25	10	20	M8	50	3
TS2515	25	15	20	M8	50	3
TS2520	25	20	20	M8	50	4
TS2522	25	22	20	M8	50	4
TS2525	25	25	20	M8	40	5
TS2530	25	30	20	M8	35	6
TS3010	30	10	20	M8	90	2
TS3015	30	15	20	M8	90	3
TS3020	30	20	20	M8	90	4
TS3025	30	25	20	M8	85	5
TS3030	30	30	20	M8	80	6
TS3040	30	40	20	M8	60	8
TS3535	35	35	20	M8	90	8
TS4020	40	20	25	M10	160	4
TS4025	40	25	25	M10	130	6
TS4030	40	30	25	M10	130	8
TS4040	40	40	25	M10	120	10

Référence	ØA (mm)	B (mm)	H (mm)	ØC (mm)	Compression Charge maxi (Kg)	Flèche maxi (mm)
TS4045	40	45	25	M10	110	12
TS5020	50	20	25	M10	250	4
TS5030	50	30	25	M10	250	8
TS5035	50	35	25	M10	230	9
TS5040	50	40	25	M10	220	10
TS5045	50	45	25	M10	210	11
TS5050	50	50	25	M10	200	12
TS6025	60	25	30	M10	400	5
TS6035	60	35	30	M10	350	7
TS6045	60	45	30	M10	300	10
TS6060	60	60	30	M10	250	12
TS7035	70	35	30	M10	450	7
TS7050	70	50	30	M10	350	10
TS7070	70	70	30	M10	300	13
TS7525	75	25	35	M12	650	5
TS7540	75	40	35	M12	500	9
TS7545	75	45	35	M12	500	10
TS7555	75	55	35	M12	450	13
TS8030	80	30	35	M14	900	7
TS8050	80	50	35	M14	750	10
TS8070	80	70	35	M14	550	13
TS10040	100	40	45	M16	1200	8
TS10060	100	60	45	M16	1100	15
TS10075	100	75	45	M16	1000	17
TS15060	150	60	45	M16	2200	14
TS15075	150	75	45	M16	2000	16

BUTEES SIMPLES - 50 shores

Cylindriques type "HS"



Type "HS"

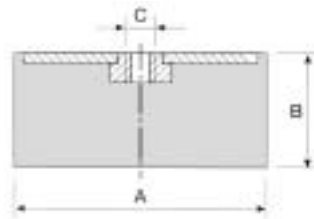

Référence	ØA (mm)	B (mm)	ØC (mm)	Compression	
				Charge maxi (kg)	Flèche maxi (mm)
HS1010	10	10	M4	10	2
HS1015	10	15	M4	8	3
HS1608	16	8	M5	15	1,5
HS1610	16	10	M5	20	1,5
HS1615	16	15	M5	20	3
HS1620	16	20	M5	20	4
HS2010	20	10	M6	30	2
HS2015	20	15	M6	25	3
HS2020	20	20	M6	25	4
HS2025	20	25	M6	25	5
HS2510	25	10	M8	50	3
HS2515	25	15	M8	50	3
HS2520	25	20	M8	50	4
HS2522	25	22	M8	50	4
HS2525	25	25	M8	40	5
HS2530	25	30	M8	35	6
HS3010	30	10	M8	90	2
HS3015	30	15	M8	90	3
HS3020	30	20	M8	90	4
HS3025	30	25	M8	85	5
HS3030	30	30	M8	80	6
HS3040	30	40	M8	60	8
HS3535	35	35	M8	90	8
HS4020	40	20	M10	160	4
HS4025	40	25	M10	150	6
HS4028	40	28	M10	150	7
HS4030	40	30	M10	150	8

Référence	ØA (mm)	B (mm)	ØC (mm)	Compression	
				Charge maxi (kg)	Flèche maxi (mm)
HS4040	40	40	M10	120	10
HS4045	40	45	M10	110	12
HS5020	50	20	M10	250	4
HS5030	50	30	M10	250	8
HS5035	50	35	M10	230	9
HS5040	50	40	M10	220	10
HS5045	50	45	M10	210	11
HS5050	50	50	M10	200	12
HS6025	60	25	M10	400	5
HS6035	60	35	M10	350	7
HS6045	60	45	M10	300	10
HS6060	60	60	M10	250	12
HS7035	70	35	M10	450	7
HS7050	70	50	M10	350	10
HS7070	70	70	M12	300	13
HS7525	75	25	M12	650	5
HS7540	75	40	M12	500	9
HS7545	75	45	M12	500	10
HS7555	75	55	M12	450	13
HS8030	80	30	M14	900	7
HS8050	80	50	M14	750	10
HS8070	80	70	M14	550	13
HS10040	100	40	M16	1200	8
HS10060	100	60	M16	1100	15
HS10075	100	75	M16	1000	17
HS15060	150	60	M16	2200	14
HS15075	150	75	M16	2000	16

DIABOLOS - 50 shores

Mâle - mâle type "TD"



Référence	ØA (mm)	ØD (mm)	B (mm)	H (mm)	ØC (mm)	Compression	
						Charge maxi (Kg)	Flèche maxi (mm)
TD2020	20	12	20	18	M6	12	2,5
TD3025	30	24	25	20	M8	40	4
TD4028	40	22	28	25	M10	60	5
TD6036	60	37	36	30	M10	90	5
TD6043	60	35	43	30	M10	70	4
TD6060	60	51	60	30	M10	150	6
TD7056	70	50	56	35	M12	220	6
TD8065	80	70	65	35	M14	400	8
TD9077	90	79	77	45	M16	500	7
TD10885	108	95	85	45	M16	800	10
TD13096	130	115	96	45	M16	1400	13

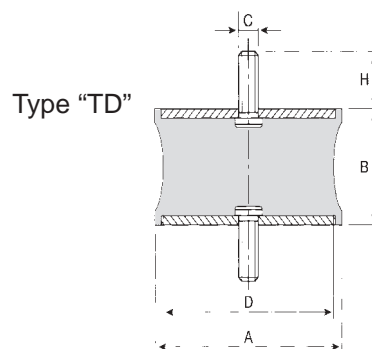

DIABOLOS - 50 shores

Femelle - femelle type "HD"



Référence	ØA (mm)	ØD (mm)	B (mm)	ØC (mm)	Compression	
					Charge maxi (kg)	Flèche maxi (mm)
HD3025	30	24	25	M8	40	4
HD4028	40	22	28	M10	60	5
HD6036	60	37	36	M10	90	5
HD6043	60	35	43	M10	70	4
HD6060	60	51	60	M10	150	6
HD7056	70	50	56	M12	220	6
HD8065	80	70	65	M12	400	8
HD9050	90	80	50	M12	800	8
HD9077	90	79	77	M16	500	7
HD10885	108	95	85	M16	800	10
HD13096	130	115	96	M16	1400	13

