

OUTILS À BROCHER : ATTACHEMENT CYLINDRIQUE

Réf.	Type	d	d1*	l	D	A	Tarif HT
ZU20.08.5010	Cyl. 20	20	8	38	40	65	520.00 €
ZU25.12.5010	Cyl. 25	25	12	55	50	88	623.00 €

* diamètre de queue du poinçon

► Les outils à brocher sont disponibles en attachement cylindrique, VDI, HSK et CAPTO. Consultez le catalogue "Brochage" pour plus d'informations.



POINÇONS TYPE PCM

► Poinçons Hexagonaux type PCM 2110 | 6150 : Ø 8 et Ø 12 mm



► Poinçons Torx type PCM 2122 | 6173 : Ø 8 et Ø 12 mm



APPAREILS À MOLETER PAR DÉFORMATION

Réf.	Désignation	Tarif HT
M0010101	Porte-Molette Basic M1 20.08.14	24.30 €
M0011603	Porte-Molette Double M7 20.08.25 réversible	142.00 €
M0011101	Kit Basique de moletage KM1-M7	317.00 €
M0010617	Porte-Molette Simple M6 20.06.20 C20 x 20 cap. 5-200	133.00 €
M0010413	Porte-molette Simple M4 20.08.20 C20 x 20	189.00 €



APPAREILS À MOLETER RÉVERSIBLES PAR COUPE

Réf.	Désignation	Tarif HT
M0010902	Porte-Molette par fraisage simple MFS 14.53.16 C16 x 16	418,00 €
M0010904	Porte-Molette par fraisage simple MFS 21.55.25 C25 x 25	418,00 €
M0011005	Porte-Molette par fraisage double MF 21.55.20 C20 x 25	652,00 €



PORTE-FRAISES SCIÉS

Réf.	Désignation	L1	D1	D2	D3	Tarif HT
T0000S2020	Porte-fraise scie Ø 20	94	Ø 20	Ø 10	Ø 5	94.40 €
T0000S2025	Porte-fraise scie Ø 25	104	Ø 20	Ø 13	Ø 8	94.40 €
T0000S2032	Porte-fraise scie Ø 32	110	Ø 20	Ø 16	Ø 8	94.40 €
T0000S2040	Porte-fraise scie Ø 40	114	Ø 20	Ø 19.5	Ø 10	94.40 €
T0000S2550	Porte-fraise scie Ø 50	141	Ø 25	Ø 24.5	Ø 13	94.40 €
T0000S2563	Porte-fraise scie Ø 63	141	Ø 25	Ø 24.5	Ø 16	94.40 €
T0000S2580	Porte-fraise scie Ø 80	160	Ø 25	Ø 34	Ø 22	147.50 €
T0000S2510	Porte-fraise scie Ø 100	160	Ø 25	Ø 39.5	Ø 22	147.50 €

TSCHORN®

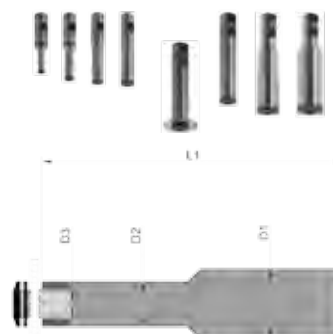

PORTE-OUTILS VDI



➤ VDI 16/20/25/30/40/50/60

BROCHAGE



➤ Appareils à brocher cylindrique | VDI | HSK | C

PORTE-OUTILS HSK



➤ HSK A | C | E | F

PORTE-FRAISES SCIES



➤ HSK A40 | E40

SUPPORTS DE MEULES



➤ HSK A40 | E40

TSUGAMI HS20 M



➤ Type 15T

MANDRINS FLOTTANTS



➤ Porte-alésoirs flottants BT30 et HSK-E40

CAPTO - ISO 26623



➤ C5 | C6

CHANGEMENT RAPIDE VDI

➤ HSK A | C | E | F



CAPTO - ISO 26623



➤ Système de changement rapide de précision



Consultez-nous