

► **Tirettes pour Machines-Outils**



TIRETTES

LA GAMME LA PLUS COMPLÈTE DU MARCHÉ
PLUS DE 200 RÉFÉRENCES

» **STOCK IMPORTANT**

Livraison **24H** avec **TNT** !
(pour toute commande passée avant 15h)



DIN 69872

Page 4 - 5



ISO 7388/2A - ISO 7388/2B

Page 6 - 9



MAS 403 BT

Page 10 - 12



JIS B 6339

Page 13 - 14



ADAPTATION

Page 15



Tirettes Spécifiques

Page 16 - 20

*Si vous ne trouvez pas
le modèle recherché,
il suffit de compléter
le plan page 23
à info@kwiktool.fr*



Tirettes Machines Bois

Page 21 - 22



EN SAVOIR PLUS ...

Ces tirettes sont fabriquées exclusivement en Europe, chez les meilleurs fabricants.

Elles sont usinées et rectifiées dans des aciers de haute performance. La qualité de ces aciers est garantie grâce aux certificats matière et aux contrôles par ultrason. De plus, les traitements thermiques spécifiques (trempe, cémentation et revenu) garantissent une résistance et une résilience répondant aux exigences les plus élevées des fabricants de machine.

Les efforts de traction supportés par les tirettes sont les suivants :

- **M12** : de 2 à 2.4 kg
- **M16** : de 6 à 7.8 kg
- **M20** : de 20 à 24 kg

IMPORTANT

L'utilisation de tirettes inadaptées ou de mauvaise qualité peut, en cas de rupture, gravement endommager la broche de la machine et être dangereux pour les opérateurs.

TOUTES NOS RÉFÉRENCES

TI0001	Page 4	TI0034	Page 6	TI0067	Page 10	TI0100	Page 11	TI0133	Page 14	TI0166	Page 20
TI0002	Page 4	TI0035	Page 6	TI0068	Page 10	TI0101	Page 10	TI0134	Page 15	TI0167	Page 20
TI0003	Page 4	TI0036	Page 6	TI0069	Page 10	TI0102	Page 11	TI0135	Page 15	TI0168	Page 18
TI0004	Page 4	TI0037	Page 6	TI0070	Page 10	TI0103	Page 12	TI0136	Page 15	TI0169	Page 19
TI0005	Page 4	TI0038	Page 6	TI0071	Page 10	TI0104	Page 12	TI0137	Page 15	TI0170	Page 20
TI0006	Page 4	TI0039	Page 7	TI0072	Page 10	TI0105	Page 12	TI0138	Page 15	TI0171	Page 10
TI0007	Page 4	TI0040	Page 7	TI0073	Page 10	TI0106	Page 12	TI0139	Page 10	TI0172	Page 10
TI0008	Page 4	TI0041	Page 7	TI0074	Page 10	TI0107	Page 12	TI0140	Page 15	TI0173	Page 10
TI0009	Page 4	TI0042	Page 7	TI0075	Page 10	TI0108	Page 12	TI0141	Page 22	TI0174	Page 10
TI0010	Page 4	TI0043	Page 7	TI0076	Page 10	TI0109	Page 12	TI0142	Page 18	TI0175	Page 21
TI0011	Page 4	TI0044	Page 7	TI0077	Page 4	TI0110	Page 12	TI0143	Page 18	TI0176	Page 10
TI0012	Page 4	TI0045	Page 8	TI0078	Page 10	TI0111	Page 12	TI0144	Page 18	TI0177	Page 21
TI0013	Page 4	TI0046	Page 8	TI0079	Page 10	TI0112	Page 12	TI0145	Page 21	TI0178	Page 10
TI0014	Page 4	TI0047	Page 8	TI0080	Page 10	TI0113	Page 12	TI0146	Page 8	TI0179	Page 10
TI0015	Page 4	TI0048	Page 8	TI0081	Page 10	TI0114	Page 12	TI0147	Page 8	TI0180	Page 22
TI0016	Page 4	TI0049	Page 8	TI0082	Page 10	TI0115	Page 12	TI0148	Page 9	TI0181	Page 11
TI0017	Page 4	TI0050	Page 8	TI0083	Page 10	TI0116	Page 12	TI0149	Page 9	TI0182	Page 11
TI0018	Page 5	TI0051	Page 9	TI0084	Page 11	TI0117	Page 12	TI0150	Page 9	TI0183	Page 11
TI0019	Page 5	TI0052	Page 9	TI0085	Page 11	TI0118	Page 13	TI0151	Page 9	TI0184	Page 11
TI0020	Page 5	TI0053	Page 9	TI0086	Page 11	TI0119	Page 13	TI0152	Page 9	TI0185	Page 11
TI0021	Page 5	TI0054	Page 9	TI0087	Page 11	TI0120	Page 13	TI0153	Page 9	TI0186	Page 11
TI0022	Page 5	TI0055	Page 9	TI0088	Page 11	TI0121	Page 13	TI0154	Page 9	TI0187	Page 11
TI0023	Page 5	TI0056	Page 9	TI0089	Page 11	TI0122	Page 13	TI0155	Page 11	TI0188	Page 11
TI0024	Page 5	TI0057	Page 8	TI0090	Page 11	TI0123	Page 13	TI0156	Page 16	TI0189	Page 11
TI0025	Page 5	TI0058	Page 8	TI0091	Page 11	TI0124	Page 13	TI0157	Page 11	TI0190	Page 11
TI0026	Page 6	TI0059	Page 8	TI0092	Page 11	TI0125	Page 13	TI0158	Page 16	TI0191	Page 4
TI0027	Page 6	TI0060	Page 11	TI0093	Page 11	TI0126	Page 13	TI0159	Page 16	TI0192	Page 11
TI0028	Page 6	TI0061	Page 10	TI0094	Page 11	TI0127	Page 13	TI0160	Page 10	TI0193	Page 11
TI0029	Page 6	TI0062	Page 10	TI0095	Page 11	TI0128	Page 13	TI0161	Page 11	TI0194	Page 11
TI0030	Page 6	TI0063	Page 10	TI0096	Page 11	TI0129	Page 13	TI0162	Page 11	TI0195	Page 4
TI0031	Page 6	TI0064	Page 10	TI0097	Page 11	TI0130	Page 13	TI0163	Page 17	TI0196	Page 4
TI0032	Page 6	TI0065	Page 10	TI0098	Page 16	TI0131	Page 14	TI0164	Page 17	TI0197	Page 21
TI0033	Page 6	TI0066	Page 10	TI0099	Page 11	TI0132	Page 14	TI0165	Page 19		

DIN 69872 | Tirette non percée avec ou sans joint

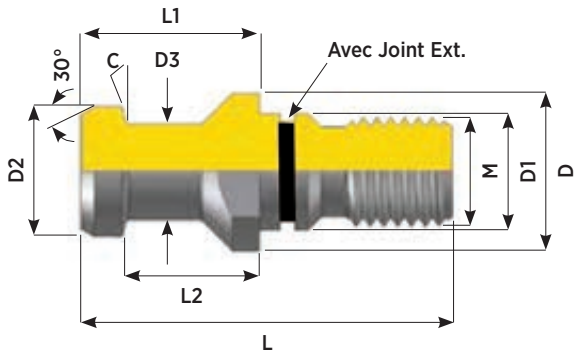

Référence	Type	DIMENSIONS EN MM									
		M	C	D	D1	D2	D3	Joint Ext.	L	L1	L2
TI0001	DIN 69872-ISO30	M12	15°	17	13	13	9		44	24	19
TI0196	DIN 69872-ISO30	M12	45°		21.5	13			48		22.5
TI0002	DIN 69872-ISO40	M16	15°	23	17	19	14		54	26	20
TI0005	DIN 69872-ISO40	M16	15°	23	17	19	14	✓	54	26	20
TI0077	DIN 69872-ISO40	M16	15°	23	17	19	14	✓	57.2	-	23.2
TI0003	DIN 69872-ISO45	M20	15°	30	21	23	17		65	30	23
TI0006	DIN 69872-ISO45	M20	15°	30	21	23	17	✓	65	30	23
TI0004	DIN 69872-ISO50	M24	15°	36	25	28	21		74	34	25
TI0007	DIN 69872-ISO50	M24	15°	36	25	28	21	✓	74	34	25

DIN 69872 | Tirette percée avec ou sans joint

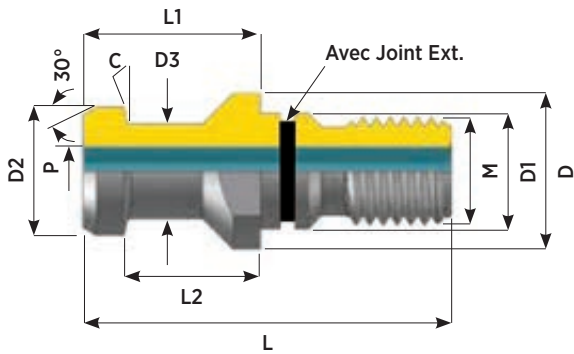

Référence	Type	DIMENSIONS EN MM										
		M	C	D	D1	D2	D3	Joint Ext.	L	L1	L2	P
TI0009	DIN 69872-ISO30	M12	15°	17	13	13	9		44	24	19	2.5
TI0008	DIN 69872-ISO30	M12	15°	17	13	13	9		44	24	19	3
TI0010	DIN 69872-ISO30	M12	15°	17	13	13	9		44	24	19	4
TI0011	DIN 69872-ISO40	M16	15°	23	17	19	14		54	26	20	7
TI0015	DIN 69872-ISO40	M16	15°	23	17	19	14	✓	54	26	20	7
TI0191	DIN 69872-ISO40	M16	15°	23	17	19	14	✓	54	29	23	7
TI0195	DIN 69872-ISO40	M16	15°	23	17	19	14	✓	54	29	23	7
TI0012	DIN 69872-ISO45	M20	15°	30	21	23	17		65	30	23	9.5
TI0016	DIN 69872-ISO45	M20	15°	30	21	23	17	✓	65	30	23	9.5
TI0014	DIN 69872-ISO50	M24	15°	36	25	28	21		74	34	25	6
TI0013	DIN 69872-ISO50	M24	15°	36	25	28	21		74	34	25	11.5
TI0017	DIN 69872-ISO50	M24	15°	36	25	28	21	✓	74	34	25	11.5

DIN 69872 | Tirette longue non percée avec ou sans joint

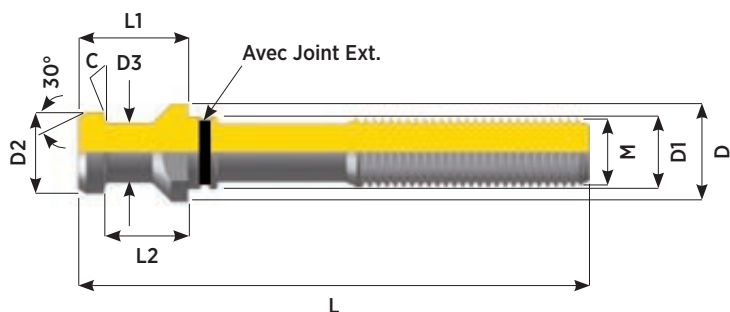

Référence	Type	DIMENSIONS EN MM											
		M	C	D	D1	D2	D3	Joint Ext.	L	L1	L2		
TI0023	DIN 69872-ISO40-CM2	M10	15°	23	17	19	14	✓	111	26	20		
TI0024	DIN 69872-ISO40-CM3	M12	15°	23	17	19	14	✓	116	26	20		
TI0025	DIN 69872-ISO40-CM4	M16	15°	23	17	19	14	✓	121	26	20		

DIN 69872 | Tirette percée avec joint exter et inter

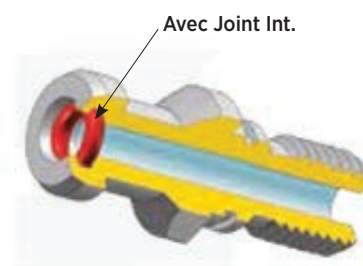
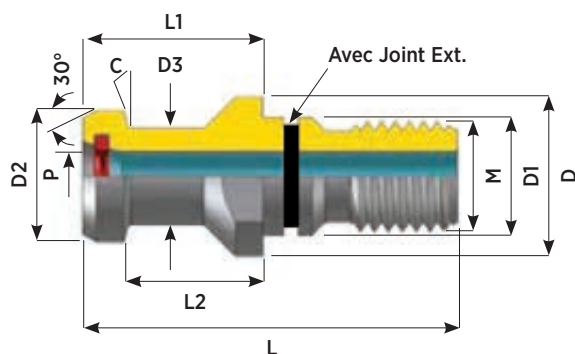

Référence	Type	DIMENSIONS EN MM												
		M	C	D	D1	D2	D3	Joint Ext.	L	L1	L2	P	Joint Int.	
TI0020	DIN 69872-ISO40	M16	15°	23	17	19	14	✓	54	26	20	7	✓	
TI0021	DIN 69872-ISO40	M16	15°	23	17	19	14	✓	54	29	23	7	✓	
TI0022	DIN 69872-ISO50	M24	15°	36	25	28	21	✓	74	34	25	11.5	✓	

DIN 69872 | Tirette semi-percée avec joint

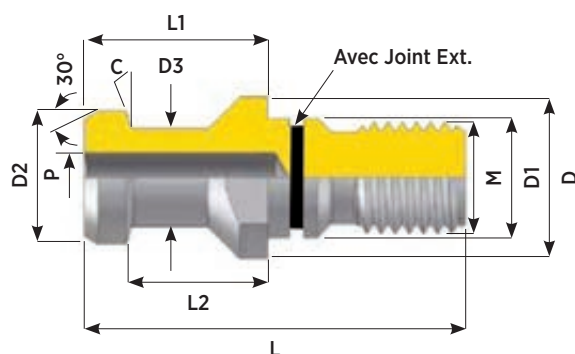

Référence	Type	DIMENSIONS EN MM											
		M	C	D	D1	D2	D3	Joint Ext.	L	L1	L2	P	
TI0018	DIN 69872-ISO40	M16	15°	23	17	19	14	✓	54	26	20	7	
TI0019	DIN 69872-ISO50	M24	15°	36	25	28	21	✓	74	34	25	11.5	

ISO 7388/2A | Tirette non percée avec ou sans joint

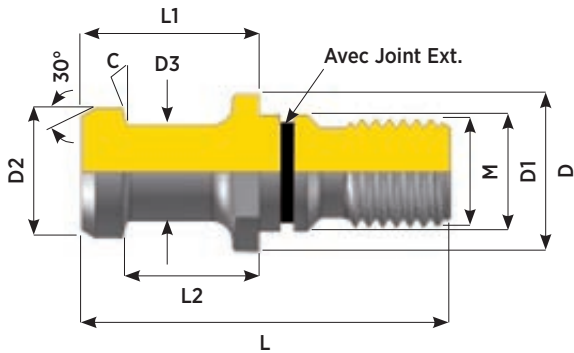

Référence	Type	DIMENSIONS EN MM										
		M	C	D	D1	D2	D3	Joint Ext.	L	L1	L2	
TI0026	7388/2A-ISO30	M12	15°	16	13	12	8		44	24	19	
TI0027	7388/2A-ISO40	M16	15°	23	17	19	14		54	26	20	
TI0030	7388/2A-ISO40	M16	15°	23	17	19	14	✓	54	26	20	
TI0028	7388/2A-ISO45	M20	15°	30	21	23	17		65	30	23	
TI0029	7388/2A-ISO50	M24	15°	36	25	28	21		74	34	25	
TI0031	7388/2A-ISO50	M24	15°	36	25	28	21	✓	74	34	25	

ISO 7388/2A | Tirette percée avec ou sans joint

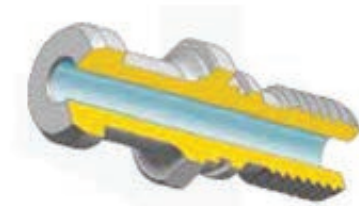
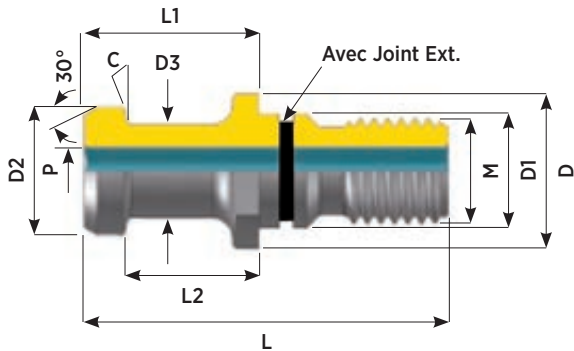

Référence	Type	DIMENSIONS EN MM										
		M	C	D	D1	D2	D3	Joint Ext.	L	L1	L2	P
TI0032	7388/2A-ISO30	M12	15°	16	13	12	8		44	24	19	3
TI0033	7388/2A-ISO30	M12	15°	16	13	12	8		44	24	19	4
TI0034	7388/2A-ISO40	M16	15°	23	17	19	14		54	26	20	7
TI0037	7388/2A-ISO40	M16	15°	23	17	19	14	✓	54	26	20	7
TI0035	7388/2A-ISO45	M20	15°	30	21	23	17		65	30	23	9.5
TI0036	7388/2A-ISO50	M24	15°	36	25	28	21		74	34	25	11.5
TI0038	7388/2A-ISO50	M24	15°	36	25	28	21	✓	74	34	25	11.5

ISO 7388/2A | Tirette semi-percée avec joint

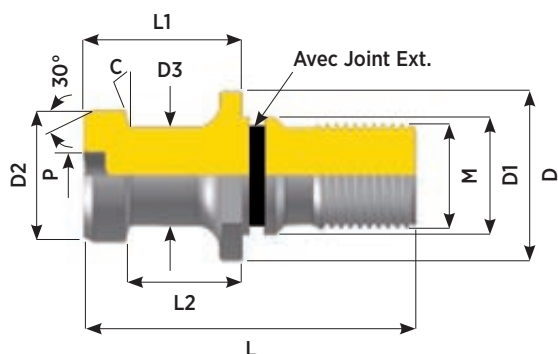

Référence	Type	DIMENSIONS EN MM										
		M	C	D	D1	D2	D3	Joint Ext.	L	L1	L2	P
TI0042	7388/2A-ISO40	M16	15°	23	17	19	14	✓	54	26	20	10x4.7
TI0043	7388/2A-ISO50	M24	15°	36	25	28	21	✓	74	34	25	10x4.7
TI0044	7388/2A-ISO50	M24	15°	36	25	28	21	✓	74	34	25	12x8.4

ISO 7388/2A | Tirette longue non percée avec ou sans joint

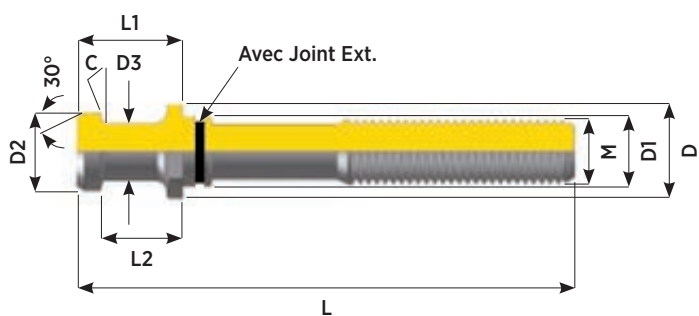

Référence	Type	DIMENSIONS EN MM										
		M	C	D	D1	D2	D3	Joint Ext.	L	L1	L2	
TI0039	7388/2A-ISO40-CM2	M10	15°	23	17	19	14	✓	111	26	20	
TI0040	7388/2A-ISO40-CM3	M12	15°	23	17	19	14	✓	116	26	20	
TI0041	7388/2A-ISO40-CM4	M16	15°	23	17	19	14	✓	121	26	20	

ISO 7388/2B | Tirette non percée avec ou sans joint

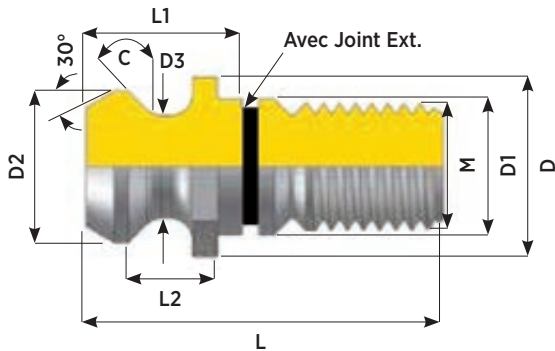

Référence	Type	DIMENSIONS EN MM									
		M	C	D	D1	D2	D3	Joint Ext.	L	L1	L2
TI0045	7388/2B-ISO30	M12	45°	17	12.5	13.35	9.3		34	11.8	8.15
TI0046	7388/2B-ISO40	M16	45°	22.5	17	18.95	12.9		44.5	16.4	11.15
TI0049	7388/2B-ISO40	M16	45°	22.5	17	18.95	12.9	✓	44.5	16.4	11.15
TI0146	7388/2B-ISO40-MAZ	M16	45°	21.8	17	18.79	12.44	✓	41.25	16.25	11.17
TI0147	7388/2B-ISO40-MAZ	M16	45°	22	17	18.79	12.44	✓	44.1	19.1	14.02
TI0047	7388/2B-ISO45	M20	45°	30	21	24	16.3		56	20.9	14.8
TI0048	7388/2B-ISO50	M24	45°	37	25	29.1	19.6		65.5	25.5	17.95
TI0050	7388/2B-ISO50	M24	45°	37	25	29.1	19.6	✓	65.5	25.5	17.95

ISO 7388/2B | Tirette longue non percée avec ou sans joint

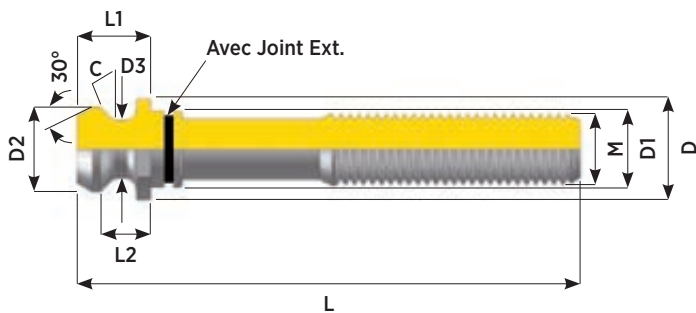

Référence	Type	DIMENSIONS EN MM									
		M	C	D	D1	D2	D3	Joint Ext.	L	L1	L2
TI0057	7388/2B-ISO40-CM2	M10	45°	22.5	17	18.95	12.9	✓	101.4	16.4	11.15
TI0058	7388/2B-ISO40-CM3	M12	45°	22.5	17	18.95	12.9	✓	106.4	16.4	11.15
TI0059	7388/2B-ISO40-CM4	M16	45°	22.5	17	18.95	12.9	✓	111.4	16.4	11.15

ISO 7388/2B | Tirette percée avec ou sans joint

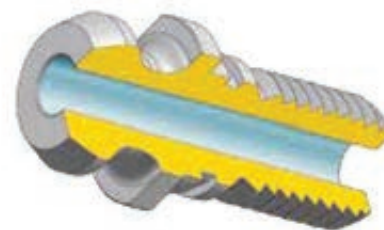
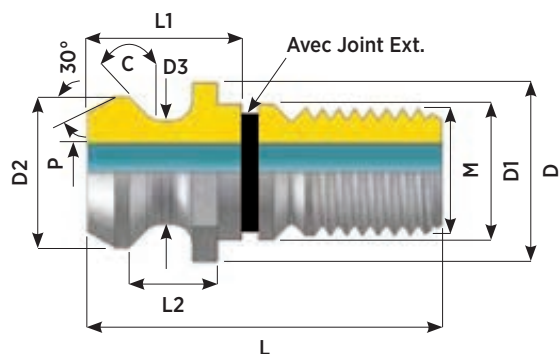

Référence	Type	DIMENSIONS EN MM										
		M	C	D	D1	D2	D3	Joint Ext.	L	L1	L2	P
TI0051	7388/2B-ISO30	M12	45°	17	12.5	13.35	9.3		34	11.8	8.15	4
TI0052	7388/2B-ISO40	M16	45°	22.5	17	18.95	12.9		44.5	16.4	11.15	7.3
TI0055	7388/2B-ISO40	M16	45°	22.5	17	18.95	12.9	✓	44.5	16.4	11.15	7.3
TI0148	7388/2B-ISO40-MAZ	M16	45°	21.8	17	18.79	12.44		41.25	16.25	11.17	7
TI0151	7388/2B-ISO40-MAZ	M16	45°	21.8	17	18.79	12.44	✓	41.25	16.25	11.17	7
TI0149	7388/2B-ISO40-MAZ	M16	45°	22	17	18.79	12.44		44.1	19.1	14.02	7
TI0152	7388/2B-ISO40-MAZ	M16	45°	22	17	18.79	12.44	✓	44.1	19.1	14.02	7
TI0053	7388/2B-ISO45	M20	45°	30	21	24	16.3		56	20.9	14.8	9.2
TI0054	7388/2B-ISO50	M24	45°	37	25	29.1	19.6		65.5	25.5	17.95	11.5
TI0056	7388/2B-ISO50	M24	45°	37	25	29.1	19.6	✓	65.5	25.5	17.95	11.5
TI0153	7388/2B-ISO50-MAZ	M24	45°	35.5	25	28.95	20.82	✓	65.2	25.4	17.58	10
TI0150	7388/2B-ISO50-MAZ	M24	45°	35.5	25	28.95	20.82		65.4	25.4	17.78	10
TI0154	7388/2B-ISO50-MAZ	M24	45°	35.5	25	28.95	20.82	✓	65.4	25.4	17.78	10

MAS 403 BT | Tirette non percée avec ou sans joint

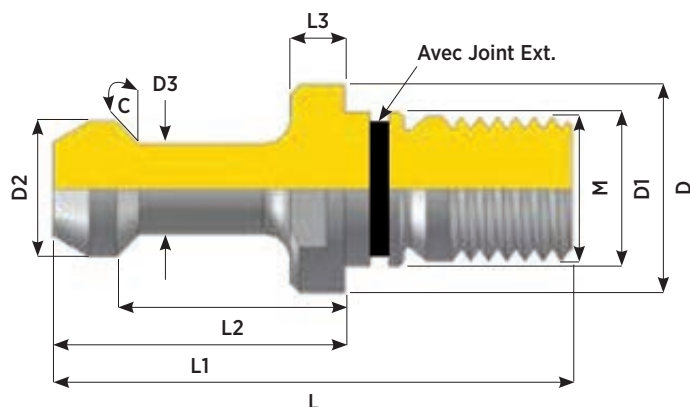

Référence	Type	DIMENSIONS EN MM										
		M	C	D	D1	D2	D3	Joint Ext.	L	L1	L2	L3
TI0061	MAS 403-BT30-45°	M12	45°	16.5	12.5	11	7		43	23	18	5
TI0160	MAS 403-BT30-45°-CHIR	M12	45°	16	13	10	6		36	20	16	3
TI0062	MAS 403-BT30-60°	M12	60°	16.5	12.5	11	7		43	23	18	5
TI0063	MAS 403-BT30-90°	M12	90°	16.5	12.5	11	7		43	23	18	5
TI0066	MAS 403-BT35-45°	M12	45°	20	13	13	8.5		48	28		
TI0065	MAS 403-BT35-60°	M12	60°	20.7	13	13.7	8.9		53	28		
TI0068	MAS 403-BT40-45°	M16	45°	23	17	15	10		60	35	28	6
TI0076	MAS 403-BT40-45°	M16	45°	23	17	15	10	✓	60	35	28	6
TI0176	MAS 403-BT40-45°-TC40	M16	45°	23	17	15	10	✓	57.15	32.15	25.15	3
TI0172	MAS 403-BT40-45°-TC40	M16	45°	23	17	15	10		57.15	32.15	25.15	6
TI0079	MAS 403-BT40-45°-TC40	M16	45°	23	17	15	10	✓	57.15	32.15	25.15	6
TI0067	MAS 403-BT40-60°	M16	60°	23	17	15	10		60	35	28	6
TI0075	MAS 403-BT40-60°	M16	60°	23	17	15	10	✓	60	35	28	6
TI0178	MAS 403-BT40-60°-TC40	M16	60°	23	17	15	10	✓	57.15	32.15	25.15	3
TI0171	MAS 403-BT40-60°-TC40	M16	60°	23	17	15	10		57.15	32.15	25.15	6
TI0174	MAS 403-BT40-60°-TC40	M16	60°	23	17	15	10	✓	57.15	32.15	25.15	6
TI0069	MAS 403-BT40-90°	M16	90°	23	17	15	10		60	35	28	6
TI0078	MAS 403-BT40-90°	M16	90°	23	17	15	10	✓	60	35	28	6
TI0101	MAS 403-BT40-90°-MITS	M16	90°	23	17	15		✓	50		18	
TI0083	MAS 403-BT40-90°-TC40	M16	90°	23	17	15	10	✓	57.15	32.15	25.15	3
TI0173	MAS 403-BT40-90°-TC40	M16	90°	23	17	15	10		57.15	32.15	25.15	6
TI0179	MAS 403-BT40-90°-TC40	M16	90°	23	17	15	10	✓	57.15	32.15	25.15	6
TI0071	MAS 403-BT45-45°	M20	45°	31	21	19	14		70	40	35	10
TI0070	MAS 403-BT45-60°	M20	60°	31	21	19	14		70	40	35	10
TI0073	MAS 403-BT50-45°	M24	45°	38	25	23	17		85	45	35	10
TI0080	MAS 403-BT50-45°	M24	45°	38	25	23	17	✓	85	45	35	10
TI0072	MAS 403-BT50-60°	M24	60°	38	25	23	17		85	45	35	10
TI0081	MAS 403-BT50-60°	M24	60°	38	25	23	17	✓	85	45	35	10
TI0074	MAS 403-BT50-90°	M24	90°	38	25	23	17		85	45	35	10
TI0082	MAS 403-BT50-90°	M24	90°	38	25	23	17	✓	85	45	35	10
TI0139	MAS 403-BT50-90°-MITS	M24	90°	38	25	24			71		23	

MAS 403 BT | Tirette percée avec ou sans joint

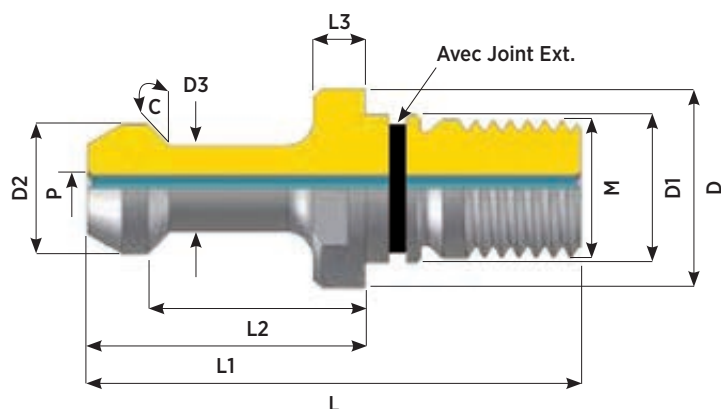

Référence	Type	DIMENSIONS EN MM											
		M	C	D	D1	D2	D3	Joint Ext.	L	L1	L2	L3	P
TI0084	MAS 403-BT30-45°	M12	45°	16.5	12.5	11	7		43	23	18	5	2.5
TI0085	MAS 403-BT30-60°	M12	60°	16.5	12.5	11	7		43	23	18	5	2.5
TI0086	MAS 403-BT30-90°	M12	90°	16.5	12.5	11	7		43	23	18	5	2.5
TI0095	MAS 403-BT40-45°	M16	45°	23	17	15	10	✓	60	35	28	6	3
TI0088	MAS 403-BT40-45°	M16	45°	23	17	15	10		60	35	28	6	4
TI0094	MAS 403-BT40-45°	M16	45°	23	17	15	10	✓	60	35	28	6	4
TI0187	MAS 403-BT40-45°-TC40	M16	45°	23	17	15	10	✓	57.15	32.15	25.15	3	3
TI0185	MAS 403-BT40-45°-TC40	M16	45°	23	17	15	10	✓	57.15	32.15	25.15	6	3
TI0182	MAS 403-BT40-45°-TC40	M16	45°	23	17	15	10		57.15	32.15	25.15	6	4
TI0188	MAS 403-BT40-45°-TC40	M16	45°	23	17	15	10	✓	57.15	32.15	25.15	6	4
TI0186	MAS 403-BT40-45°-TC40	M16	45°	23	17	15	10	✓	57.15	32.15	25.15	6	4.5
TI0161	MAS 403-BT40-45°-CINCI	M16	45°	22.2	17	15	10.3		67.3	36.6	29	5	3.8
TI0162	MAS 403-BT40-45°-CINCI	M16	45°	22.2	17	15	10.3		67.3	39.4	31.4	5	3.8
TI0096	MAS 403-BT40-60°	M16	60°	23	17	15	10	✓	60	35	28	6	3
TI0087	MAS 403-BT40-60°	M16	60°	23	17	15	10		60	35	28	6	4
TI0093	MAS 403-BT40-60°	M16	60°	23	17	15	10	✓	60	35	28	6	4
TI0190	MAS 403-BT40-60°-TC40	M16	60°	23	17	15	10	✓	57.15	32.15	25.15	3	3
TI0189	MAS 403-BT40-60°-TC40	M16	60°	23	17	15	10	✓	57.15	32.15	25.15	6	3
TI0181	MAS 403-BT40-60°-TC40	M16	60°	23	17	15	10		57.15	32.15	25.15	6	4
TI0184	MAS 403-BT40-60°-TC40	M16	60°	23	17	15	10	✓	57.15	32.15	25.15	6	4
TI0155	MAS 403-BT40-90°-MITS	M16	90°	23	17	15		✓	50		18		3
TI0060	MAS 403-BT40-90°	M16	90°	23	17	15	10	✓	60	35	28	6	3
TI0089	MAS 403-BT40-90°	M16	90°	23	17	15	10		60	35	28	6	4
TI0097	MAS 403-BT40-90°	M16	90°	23	17	15	10	✓	60	35	28	6	4
TI0194	MAS 403-BT40-90°-TC40	M16	90°	23	17	15	10	✓	57.15	32.15	25.15	3	3
TI0193	MAS 403-BT40-90°-TC40	M16	90°	23	17	15	10	✓	57.15	32.15	25.15	6	3
TI0183	MAS 403-BT40-90°-TC40	M16	90°	23	17	15	10		57.15	32.15	25.15	6	4
TI0192	MAS 403-BT40-90°-TC40	M16	90°	23	17	15	10	✓	57.15	32.15	25.15	6	4
TI0091	MAS 403-BT50-45°	M24	45°	38	25	23	17		85	45	35	10	6
TI0100	MAS 403-BT50-45°	M24	45°	38	25	23	17	✓	85	45	35	10	6
TI0090	MAS 403-BT50-60°	M24	60°	38	25	23	17		85	45	35	10	6
TI0099	MAS 403-BT50-60°	M24	60°	38	25	23	17	✓	85	45	35	10	6
TI0092	MAS 403-BT50-90°	M24	90°	38	25	23	17		85	45	35	10	6
TI0102	MAS 403-BT50-90°	M24	90°	38	25	23	17	✓	85	45	35	10	6
TI0157	MAS 403-BT50-90°-MITS	M24	90°	38	25	24		✓	71		23		8

MAS 403 BT | Tirette percée avec joint inter et exter

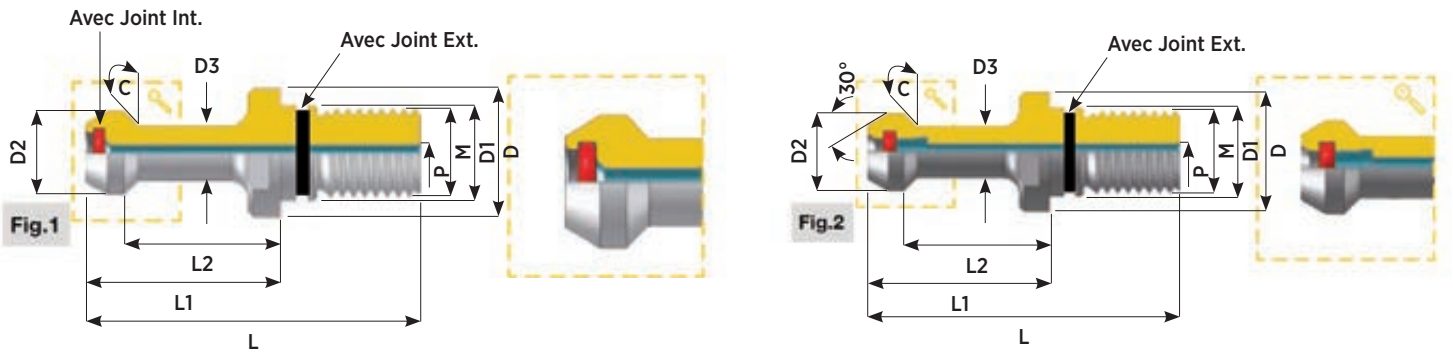

Référence	Type	DIMENSIONS EN MM												
		M	C	D	D1	D2	D3	Joint Ext.	L	L1	L2	P	Joint Int.	Fig.
TI0103	MAS 403-BT40-45°	M16	45°	23	17	15	10	✓	60	35	28	3	✓	Fig. 1
TI0104	MAS 403-BT40-45°	M16	45°	23	17	15	10	✓	60	35	28	3	✓	Fig. 2
TI0105	MAS 403-BT40-60°	M16	60°	23	17	15	10	✓	60	35	28	3	✓	Fig. 1
TI0106	MAS 403-BT50-45°	M24	45°	38	25	23	17	✓	85	45	35	6	✓	Fig. 1
TI0107	MAS 403-BT50-60°	M24	60°	38	25	23	17	✓	85	45	35	6	✓	Fig. 1
TI0108	MAS 403-BT50-90°	M24	90°	38	25	23	17	✓	85	45	35	6	✓	Fig. 1

MAS 403 BT | Tirette longue non percée sans joint

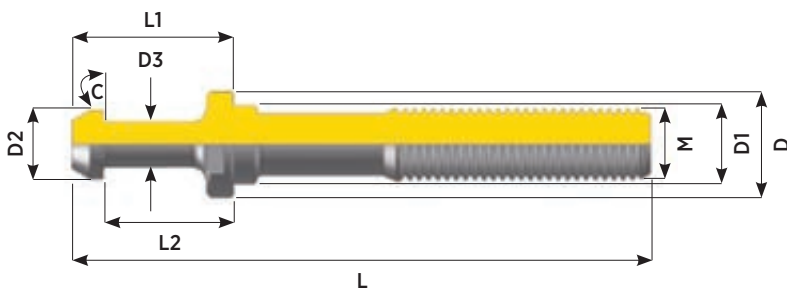

Référence	Type	DIMENSIONS EN MM										
		M	C	D	D1	D2	D3	Joint Ext.	L	L1	L2	
TI0109	MAS 403-BT40-45°-CM2	M10	45°	23	17	15	10		120	35	28	
TI0110	MAS 403-BT40-45°-CM3	M12	45°	23	17	15	10		120	35	28	
TI0111	MAS 403-BT40-45°-CM4	M16	45°	23	17	15	10		125	35	28	
TI0112	MAS 403-BT40-60°-CM2	M10	60°	23	17	15	10		120	35	28	
TI0113	MAS 403-BT40-60°-CM3	M12	60°	23	17	15	10		120	35	28	
TI0114	MAS 403-BT40-60°-CM4	M16	60°	23	17	15	10		125	35	28	
TI0115	MAS 403-BT40-90°-CM2	M10	90°	23	17	15	10		120	35	28	
TI0116	MAS 403-BT40-90°-CM3	M12	90°	23	17	15	10		120	35	28	
TI0117	MAS 403-BT40-90°-CM4	M16	90°	23	17	15	10		125	35	28	

JIS B 6339 | Tirette non percée avec ou sans joint

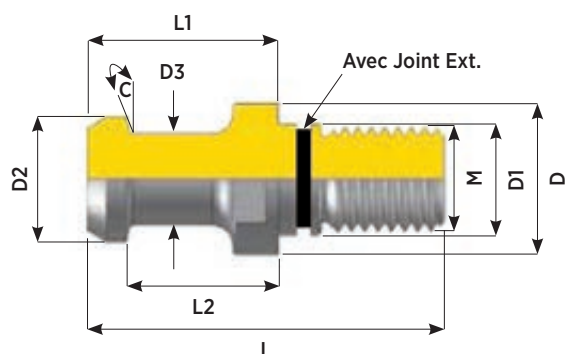

Référence	Type	DIMENSIONS EN MM									
		M	C	D	D1	D2	D3	Joint Ext.	L	L1	L2
TI0118	JIS B 6339-BT30	M12	15°	16.5	12.5	12	8		43	23.4	18.4
TI0119	JIS B 6339-BT40	M16	15°	23	17	19	14	✓	54	29	23
TI0120	JIS B 6339-BT50	M24	15°	38	25	28	21	✓	74	34	25

JIS B 6339 | Tirette percée avec ou sans joint

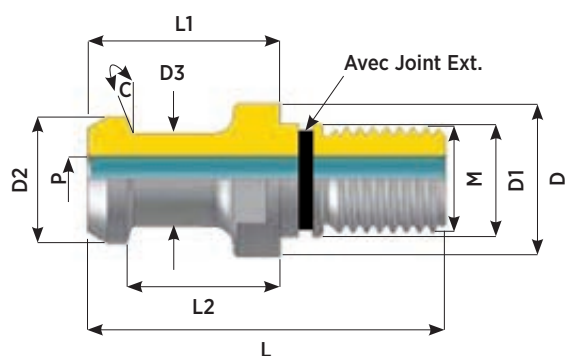

Référence	Type	DIMENSIONS EN MM										
		M	C	D	D1	D2	D3	Joint Ext.	L	L1	L2	P
TI0121	JIS B 6339-BT30	M12	15°	16.5	12.5	12	8		43	23.4	18.4	3
TI0129	JIS B 6339-BT30	M12	15°	16.5	12.5	12	8		43	23.4	18.4	4
TI0127	JIS B 6339-BT40	M16	15°	23	17	19	14	✓	54	29	23	3
TI0126	JIS B 6339-BT40	M16	15°	23	17	19	14	✓	54	29	23	4
TI0125	JIS B 6339-BT40	M16	15°	23	17	19	14	✓	54	29	23	5
TI0124	JIS B 6339-BT40	M16	15°	23	17	19	14	✓	54	29	23	5.5-4
TI0123	JIS B 6339-BT40	M16	15°	23	17	19	14	✓	54	29	23	6
TI0130	JIS B 6339-BT40	M16	15°	23	17	19	14		54	29	23	7
TI0122	JIS B 6339-BT40	M16	15°	23	17	19	14	✓	54	29	23	7
TI0128	JIS B 6339-BT50	M24	15°	38	25	28	21	✓	74	34	25	10

JIS B 6339 | Tirette longue non percée *sans joint*

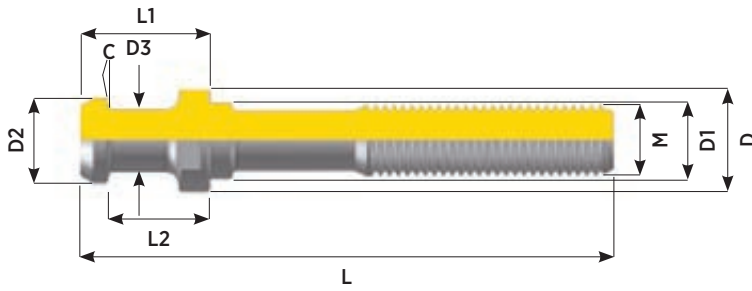

Référence	Type	DIMENSIONS EN MM									
		M	C	D	D1	D2	D3	Joint Ext.	L	L1	L2
TI0131	JIS B 6339-BT40-CM2	M10	15°	23	17	19	14		114	29	23
TI0132	JIS B 6339-BT40-CM3	M12	15°	23	17	19	14		114	29	23
TI0133	JIS B 6339-BT40-CM4	M16	15°	23	17	19	14		119	29	23

ADAPTATION | Tirette non percée sans joint

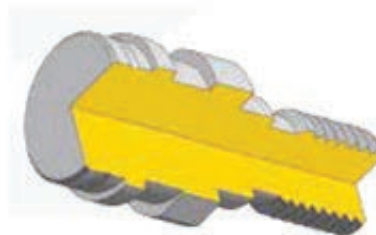
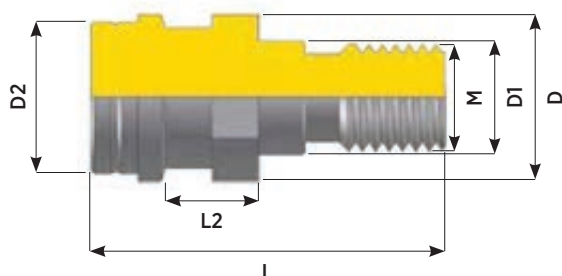

Référence	Type	DIMENSIONS EN MM					
		M	D	D1	D2	L	L2
TI0136	Adaptation TC40 sur DIN40	M16	25.3	17	25	53.1	14.52
TI0140	Adaptation BT40 sur DIN40	M16	25.3	17	25	56	17.54
TI0137	Adaptation TC/BT50 sur DIN50	M24	39.6	25	39.6	65	14

ADAPTATION | Tirette percée sans joint

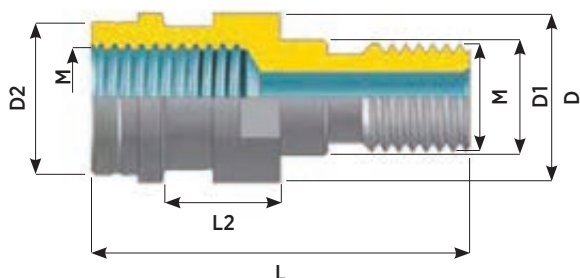

Référence	Type	DIMENSIONS EN MM					
		M	D	D1	D2	L	L2
TI0134	Adaptation TC40 sur DIN40	M16	25.3	17	25	53.1	14.52
TI0138	Adaptation BT40 sur DIN40	M16	25.3	17	25	56	17.54
TI0135	Adaptation TC/BT50 sur DIN50	M24	39.6	25	39.6	65	14

Tirette Spécifique CB FERRARI | Tirette perçée sans joint

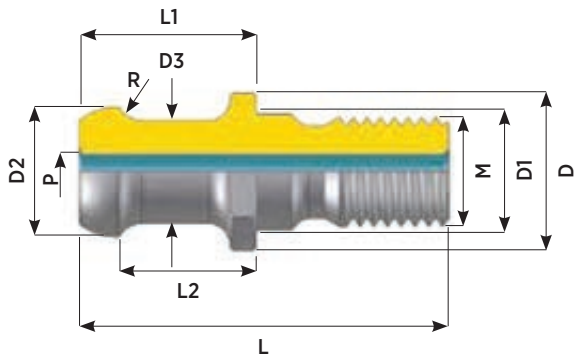

Référence	Type	DIMENSIONS EN MM									
		M	R	D	D1	D2	D3	L	L1	L2	P
TI0156	CB FERRARI-ISO30	M12	3.4		13	12		44		19.5	3
TI0158	CB FERRARI-ISO40	M16	3.7	23	17	19	15	54	26	20.31	5
TI0159	CB FERRARI-ISO50	M24	4.3		25	28		74		25.5	6

Tirette Spécifique CB FERRARI | Tirette perçée sans joint avec écrou

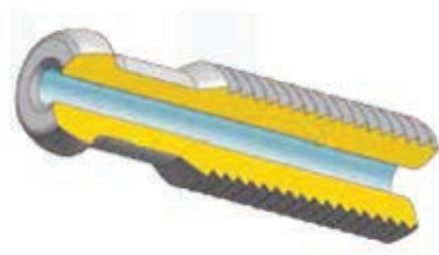
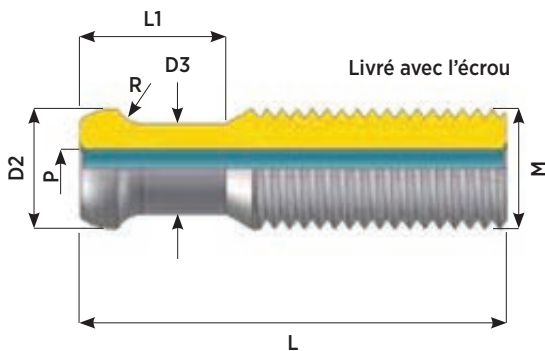

Référence	Type	DIMENSIONS EN MM						
		M	R	D2	D3	L	L1	P
TI0098	CB FERRARI-ISO40	M16	3.7	16	12	57	18.5	5

Tirette Spécifique CORREA | Tirette non perçée *sans joint*

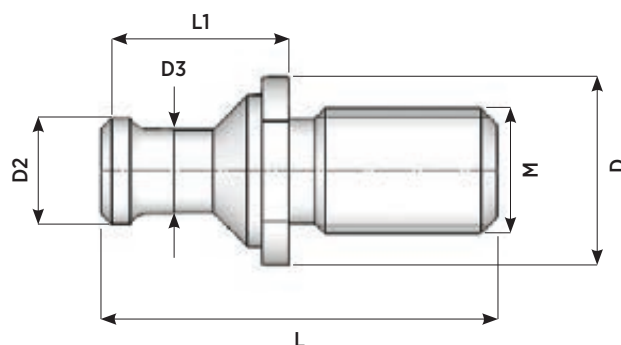

Référence	Type	DIMENSIONS EN MM					
		M	D	D2	D3	L	L1
TI0163	CORREA-ISO50	M24	36	20	16	76	36

Tirette Spécifique CORTINI | Tirette non perçée *sans joint*

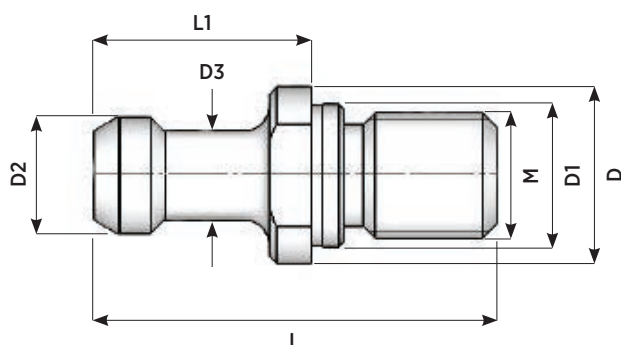

Référence	Type	DIMENSIONS EN MM						
		M	D	D1	D2	D3	L	L1
TI0164	CORTINI-ISO30	M12	16	13	10	7	39	21

Tirette Spécifique FAMUP | Tirette non perçée *sans joint*

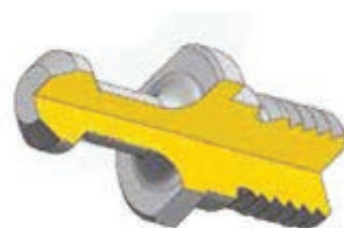
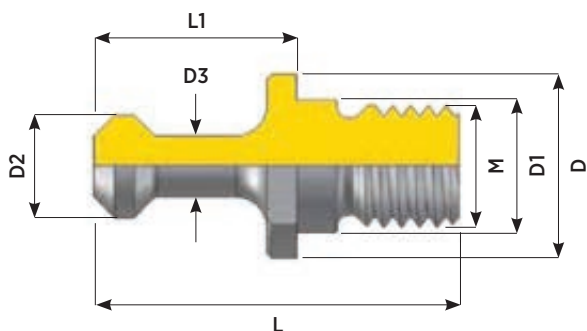

Référence	Type	DIMENSIONS EN MM						
		M	D	D1	D2	D3	L	L1
TI0142	FAMUP-ISO30	M12	16	13	9.8	5.8	40	20
TI0143	FAMUP-ISO40	M16	23	17	13.8	9.8	55	27
TI0144	FAMUP-ISO40	M16	23	17	13.8	9.8	58	30

Tirette Spécifique GLORIA | Tirette non perçée *sans joint*

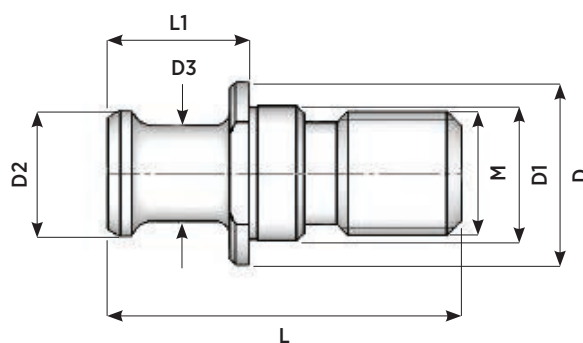

Référence	Type	DIMENSIONS EN MM						
		M	D	D1	D2	D3	L	L1
TI0168	GLORIA-ISO40	M16	23	17	16	12	45	18

Tirette Spécifique OLIVETTI | Tirette non percée sans joint

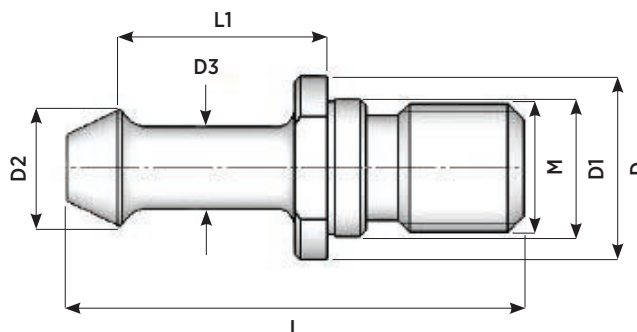

Référence	Type	DIMENSIONS EN MM						
		M	D	D1	D2	D3	L	L1
TI0169	OLIVETTI-ISO40	M16	23	17	14.3	10	58	33

Tirette Spécifique ISO 20 | Tirette non percée sans joint

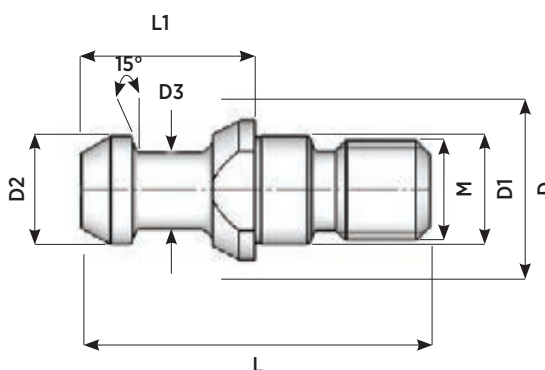

Référence	Type	DIMENSIONS EN MM						
		M	D	D1	D2	D3	L	L1
TI0165	ISO 20	M8	11	8.5	8.5	6	28	14

Tirette Spécifique RAMBAUDI | Tirette non percée *sans joint*

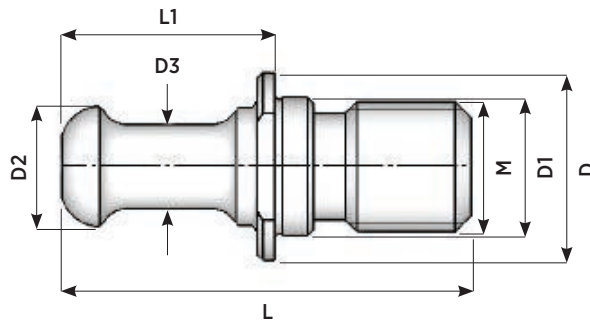

Référence	Type	DIMENSIONS EN MM						
		M	D	D1	D2	D3	L	L1
TI0166	RAMBAUDI-ISO40	M16	24	17	14.6	10	52	27
TI0167	RAMBAUDI-ISO50	M24	35.8	25	20	16	79.5	39.5

Tirette Spécifique SECMU | Tirette non percée *sans joint*

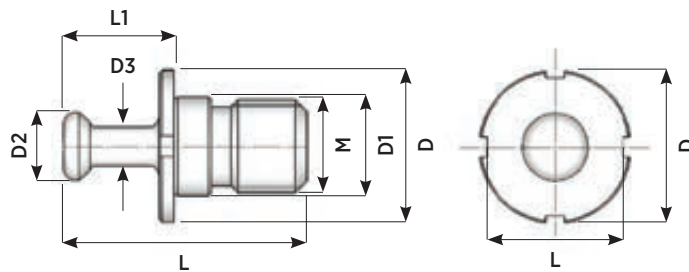

Référence	Type	DIMENSIONS EN MM							
		M	D	D1	D2	D3	L	L1	C
TI0170	SECMU-ISO50	M24	40	25	17.5	9.8	64	29	36

Tirette Machines Bois ALBERTI | Tirette non perçée sans joint

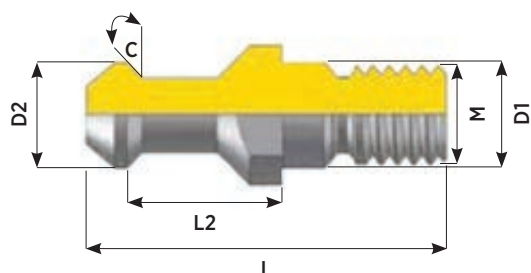

Référence	Type	DIMENSIONS EN MM					
		M	C	D1	D2	L	L2
TI0175	ALBERTI-ISO20	M6	45°	6.5	7	23	9.5
TI0177	ALBERTI-ISO25	M8	45°	9	10	31	13.5
TI0197	ALBERTI-ISO30	M12	45°	13	12.8	44	19

Tirette Machines Bois BIESSE | Tirette non perçée sans joint

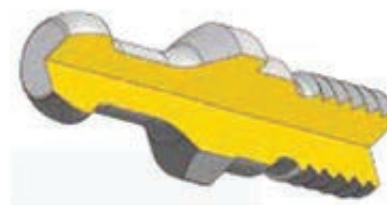
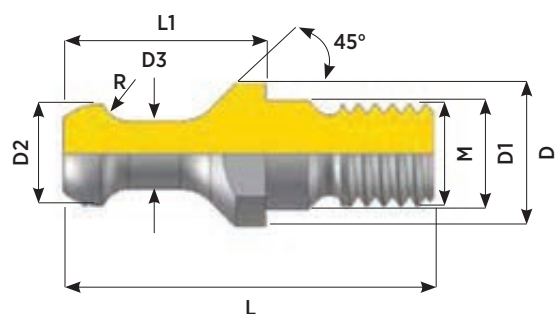

Référence	Type	DIMENSIONS EN MM							
		M	R	D	D1	D2	D3	L	L1
TI0145	BIESSE-ISO30	M12	3.2	17	13	12	8	44	24

Tirette Machines Bois CMS | Tirette non perçée sans joint

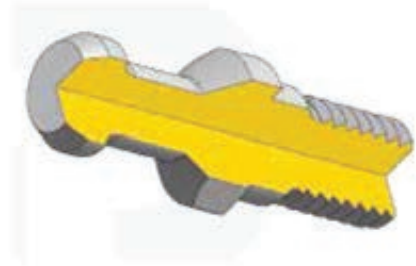
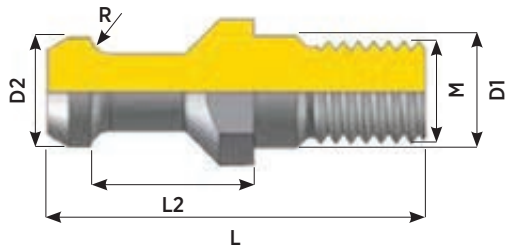

Référence	Type	DIMENSIONS EN MM					
		M	R	D1	D2	L	L2
TI0141	CMS-ISO30	M12	2.4	13	12.8	44	19

Tirette Machines Bois SCM | Tirette non perçée sans joint

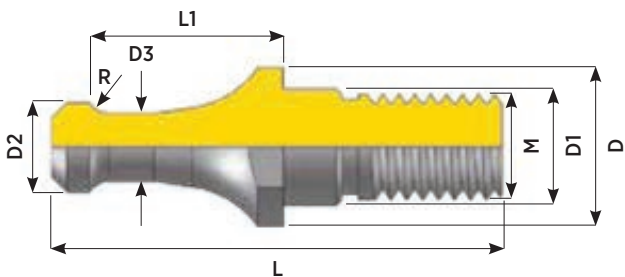

Référence	Type	DIMENSIONS EN MM								
		M	R	D	D1	D2	D3	L	L1	L2
TI0180	SCM-ISO30	M10	2.3	15	11	8.5	6.5	42.5	21.9	18.3

COMMANDEZ VOTRE TIRETTE SPÉCIALE

Veillez indiquer dans le tableau vos cotes en vous référant au plan ci-dessous.

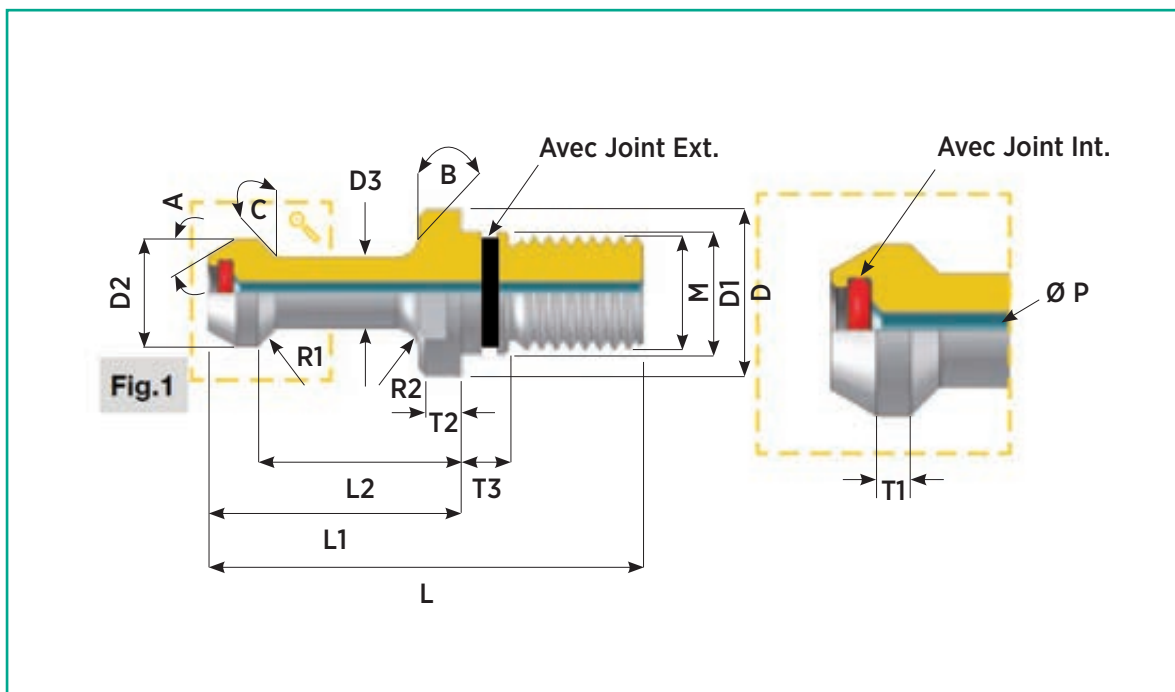

Informations à nous retourner pour votre commande

A	B	C	D	D1	D2	D3	M	J ext	P
.....

L	L1	L2	T1	T2	T3	R1	R2	J int
.....

Marque de la machine

Modèle de la machine

Revendeur :

Client :